

RESIDENTIAL COLLECTION

DESIGNER WALLS & FENCES



MODULAR WALLS

WHY MODULARWALLS™?

The grand visual appeal associated with brick rendered walls can be recreated with ModularWalls using a range of stylish collections including the grand EstateWall, the cost-effective SlimWall or the popular VogueWall.

ModularWalls are not only faster, easier and less expensive to install, but visually provide the same high-end appearance when compared to a traditional masonry wall. Our walls also have acoustic benefits, with a typical 20+dB reduction in audible noise. The modern modular post and panel system can be installed in a matter of days and requires no strip footings, specialised skills or heavy machinery.

Cost effective superior looks

With the surge in demand for bricks and the increasing cost of bricklayers, many homeowners are looking to alternative wall solutions to emulate the look of masonry rendered walls. This saves renovators from incurring high costs and hassles associated with masonry construction, and can eliminate the need to apply for council approval.

Reduce noise

ModularWalls has been National Acoustic Laboratory tested and rated. Typically, you can expect up to a fourfold audible reduction in traffic noise, keeping both traffic and neighbours at bay.

Private and secure

Whether you want to create privacy in your garden, around your pool, or in your front yard, ModularWalls offer a range of solutions with standard heights available from 900mm up to 3000mm. Enjoy the security and privacy of a masonry wall for a fraction of the price.

Versatile

Customise the look of your wall, from a simple acrylic paint to a Tuscan style render. Whatever the style of your home, be it Federation, ultra-modern or anything in between, there is a style and finish to suit. Your wall can be enhanced with other materials such as aluminium or timber slats, pickets or wrought iron to add a truly individual look. Lighting, audio or security systems can also easily be accommodated, as all walls are internally recessed to accept wiring for a number of services.

Strong and durable

Composite panel technology provides a panel that is strong, lightweight, and will not rot, warp or corrode. Virtually maintenance free, our modular walls display amazing rigidity in any situation. The unique post design allows for any future ground movement without affecting the walls integrity, meaning it will not crack like other masonry wall materials.

Designed and manufactured in Australia

We invented the modular wall, and continue to improve and diversify our designs and product range each year. We have recently relocated into our 'state of the art' manufacturing facility in Sydney, NSW, and service demand throughout Australia and internationally.



EstateWall with flush post capping



PEACE AND QUIET

ModularWalls has been National Acoustic Laboratory tested and rated. Typically, you can expect an acoustic benefit of around 20+ dB reduction in audible noise. This makes ModularWalls the perfect choice if you live on a busy road or simply want to reduce neighbourhood noise and transform your home into a quieter, more peaceful oasis.

ACHIEVE A 4-FOLD NOISE REDUCTION (TYPICAL)

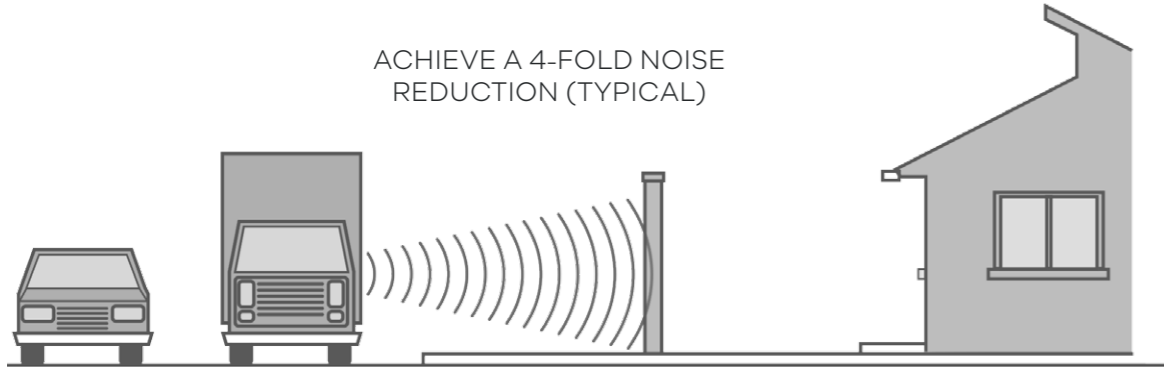

SlimWall with Classic post and expressed joint

Do it yourself or have it installed

Every residential customer has a choice to either:

DIY - Install yourself

ModularWalls products have been designed with the DIY customer in mind. Installation is fast and easy, and does not require the use of heavy machinery, extensive digging or specialist trades. You will be supported through the installation process with Head Office assistance on correct material choice and 3D drawings to guide you along the way. We also offer 7-day phone support for all DIY customers.

The installation process comprises of a few simple steps:

- Step 1.** Dig holes
- Step 2.** Concrete posts
- Step 3.** Slide in panels
- Step 4.** Custom finish as desired

For detailed installation instructions, please download the Installation Guide from our website, modularwalls.com.au, or watch our installation videos.

Professional - Have your wall installed by a skilled trade partner

Some people aren't so handy or simply don't have the time. Let one of our skilled tradesmen come to your site and give you a no obligation quote and site assessment.

A tradesmen can have local knowledge with councils and understand ground conditions, which is a great advantage and provides a more seamless process. ModularWalls offer an Australia-wide network of professional installers who can come to your property and provide a free, no obligation quote. They will provide all the tools, arrange the supply of materials and have the skills to deliver a turnkey solution from start to finish.



IDEAL FOR STEPPED BLOCKS

No need for an expensive stand-alone block retaining wall with a fence on top. Combine any of our modular walls with our specialised retaining panel to maintain a seamless look along the breadth of your wall.

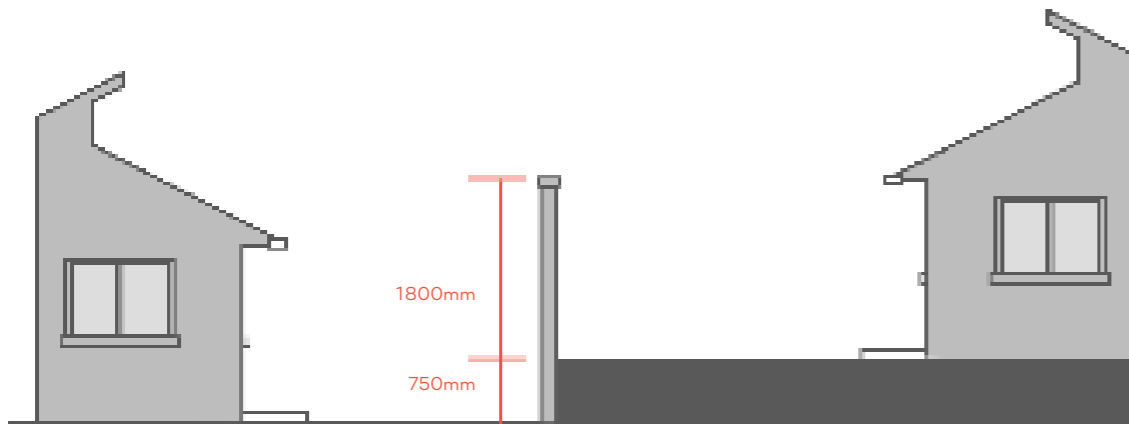

VogueWall Classic stand-alone retaining

Retaining made easy

Sloping and uneven sites can create many challenges. Our range of retaining options can hold up to 750mm of soil, and can seamlessly integrate into a boundary wall, creating a stylish and aesthetically appealing wall solution for your home.

This saves a significant amount of time, money and space by avoiding the need to build a separate retaining wall which occupies a sizeable amount of land.

- Up to 750mm of retaining
- 2.5kPa - 10kPa surcharge live load options available
- Stand-alone retaining or integrated retaining with boundary wall

Create a stand-alone retaining wall

Homeowners and landscapers are all too familiar with the challenge of levelling a sloping garden or creating attractive and functional planter boxes.

Our walls can be used as a stand-alone retaining wall, producing an affordable and aesthetically pleasing solution that compliments the look of your property.

Integrate retaining with our range of boundary walls

Our composite fibre cement retaining panels can be built into your modular wall to extend your retaining requirements with a consistent and seamless look along the breadth of your wall.

This integrated solution delivers pleasing aesthetics unmatched by alternative solutions, with no more ugly concrete at the base of your wall.

As there is no requirement for concrete blocks or strip footings, our retaining solutions are easier and faster to install, and can also be customised to enhance the overall appearance of your home.



VogueWall Aluminium planter box retaining

WALL & FENCE COLLECTIONS

SLIMWALL™

Panel thickness

50mm

Post options

Classic: 90mm x 90mm

Aluminium: 75mm x 75mm

Height

Classic: Up to 2.1m

Aluminium: Up to 2.1m



VOGUEWALL™

Panel thickness

75mm

Post options

Classic: 250mm x 150mm

Aluminium: 100mm x 100mm

Height

Classic: Up to 3.0m

Aluminium: Up to 2.4m



ESTATEWALL™

Panel thickness

100mm

Post options

Classic: 350mm x 235mm

Height

Classic: Up to 3.0m



SlimWall™

Our premium fencing solution



SlimWall with Classic post



SlimWall Classic boundary wall for pool area

Our premium fencing solution, SlimWall, has a sleek and modern design that can seamlessly match the existing style of any home. As Australia's fastest growing fencing product, SlimWall can transform your garden into a stylish outdoor oasis.

- Our most cost effective solution
- Proven acoustic performance
- Durable, lightweight modular construction
- Quick and easy installation
- Easily customised
- Expressed joint option available
- Available with either our Classic or Aluminium post



SlimWall Classic with integrated lighting

Available heights: Up to 2.1m

Panel thickness: 50mm

Wall capping: Flush finish

Post capping: Flush finish

Aluminium post:
75mm (face) x 75mm (depth)

Classic post:
90mm (face) x 90mm (depth)

Retaining: up to 500mm
(2.5kpa surcharge live loads)

Aluminium post



Classic post

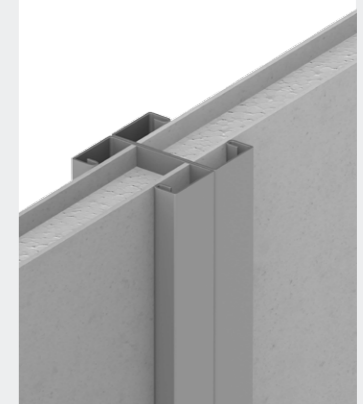

VogueWall™

Our most popular wall



VogueWall Aluminium with integrated post lighting

VogueWall is designed to closely mirror the dimensions of a single brick wall with piers. It is our most popular wall style as it is so versatile. Whilst decorative in its own right, VogueWall will make a statement as a front wall, but is also the perfect solution for a boundary wall, feature wall, pool wall, privacy wall or acoustic barrier.

- Offers superior noise reduction qualities
- Customise with lighting, letterboxes, slats and gates
- Rated for all wind regions in Australia
- Exposed joint option available
- Available with either our Classic or Aluminium post

Available heights:

Up to 3.0m (Classic post)
Up to 2.4m (Aluminium post)

Panel thickness: 75mm

Wall capping: Flush or external finish

Post capping: Flush or external finish

Aluminium post:

100mm (face) x 100mm (depth)

Classic post:

250mm (face) x 150mm (depth)

Retaining: up to 750mm

(2.5kpa surcharge live loads)

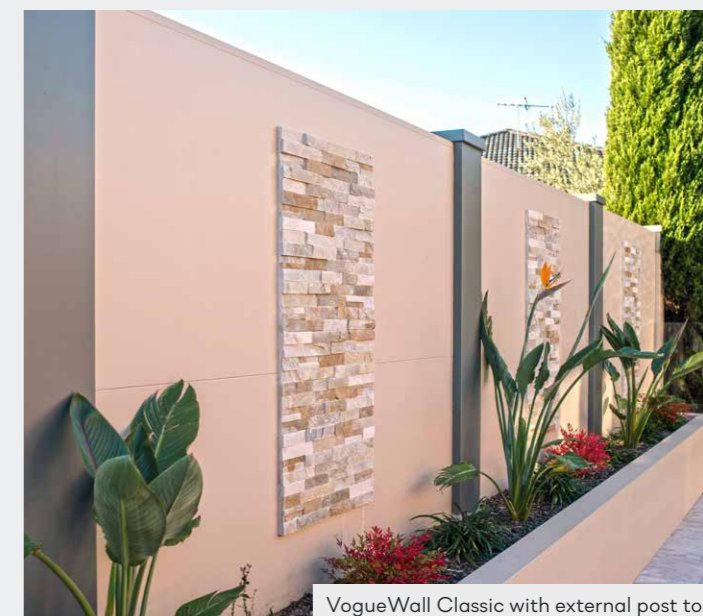

VogueWall Classic with external post tops

Aluminium post



Classic post

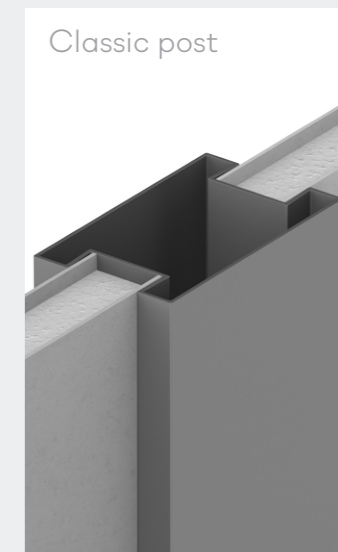

VogueWall with Classic post

EstateWall™

Make a statement with grand proportions



EstateWall with slats and customised driveway gate

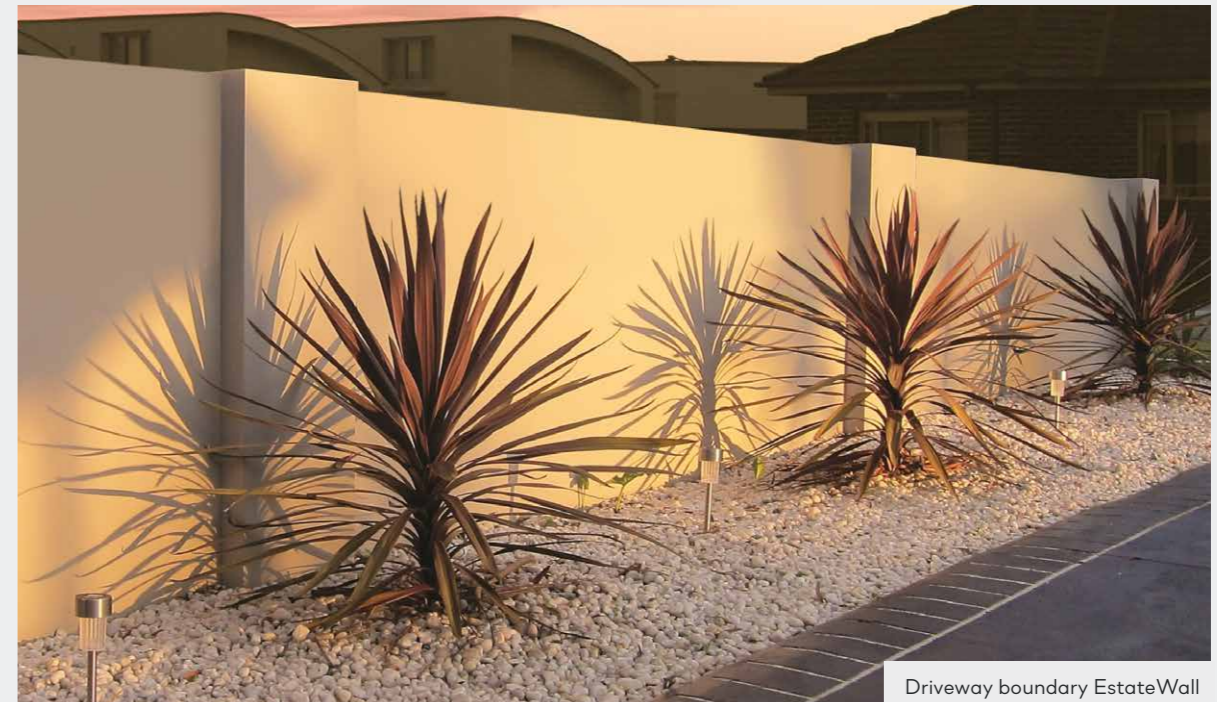

Driveway boundary EstateWall

EstateWall is designed to closely mirror the dimensions of a brick wall with large piers. It is a premium option and ideal for decorative front walls that make a grand statement.

It can also be suited for front walls, premium boundary walls, acoustic walls and security perimeters. It is also acoustically tested and rated as a sound barrier.

- Offers superior noise reduction qualities
- Easily mount a letter box into the post or panel
- Add lighting and gates for secure boundaries
- Add decorative slat infills if desired
- Rated for all wind regions in Australia
- Can retain up to 750mm

Available heights: Up to 3.0m

Panel thickness: 100mm

Wall capping: Flush or external finish

Post capping: Flush or external finish

Post: 350mm (face) x 235mm (depth)

Retaining: up to 750mm
(2.5kpa surcharge live loads)



Front EstateWall with slats

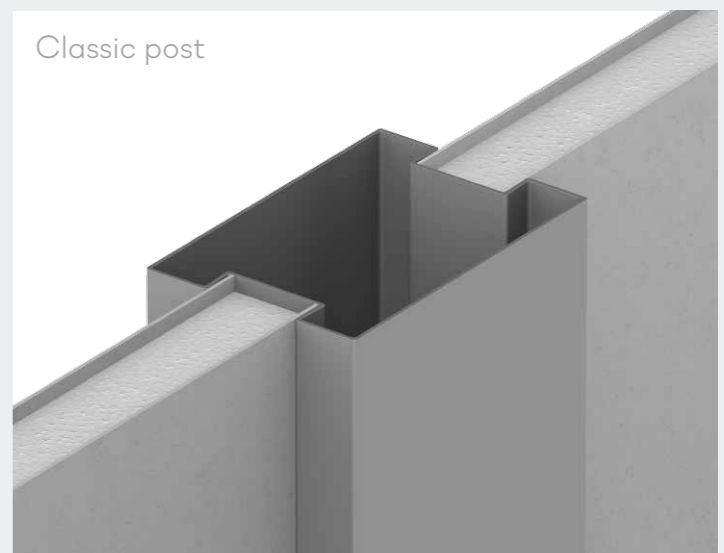

Classic post

MODULARWALLS - THE SUPERIOR ALTERNATIVE

ModularWalls provides better aesthetics and superior performance capabilities relative to traditional walls and fences - but at a more affordable price.

Highly acoustic, fast to install, easy to maintain, and great to look at - it is not surprising that ModularWalls is experiencing strong demand right throughout Australia.



EstateWall with customised gate

Simply better...

ModularWalls products have been designed and manufactured in Australia, for Australian conditions. Our range of boundary wall solutions compare favourably to other traditional fence and wall alternatives.

ModularWalls v timber fencing:

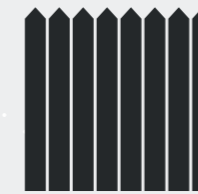

- ✓ Superior aesthetics
- ✓ Better acoustic performance
- ✓ Will not rot or discolour
- ✓ Much longer design life

ModularWalls v metal fencing:

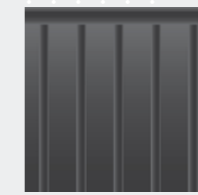

- ✓ Superior aesthetics
- ✓ Better acoustic performance
- ✓ Panels will not rust or dent
- ✓ Allows lighting and retaining

ModularWalls v slatted fencing:



- ✓ Better acoustics and privacy
- ✓ Stronger structure
- ✓ Greater durability
- ✓ More economical

ModularWalls v brick walls:

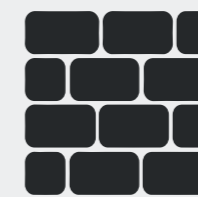

- ✓ Significantly more affordable
- ✓ Will not crack over time
- ✓ Easier and faster to install
- ✓ No strip footings required

CUSTOMISE TO YOUR STYLE

- Pedestrian gates
- Texture or render finish
- Letterboxes
- Security and intercoms
- Stack stone cladding
- Timber, steel or laser-cut infills
- Lighting
- Decorative cappings



Customised VogueWall with stone veneer



SlimWall with expressed joint



Customised VogueWall with stencil render



VogueWall with integrated lighting



EstateWall with slats and customised sliding gate



EstateWall with customised stone posts



EstateWall with laser-cut infills



Modular panel gate

TECHNICAL INFORMATION

TYPICAL WALL CONSTRUCTION

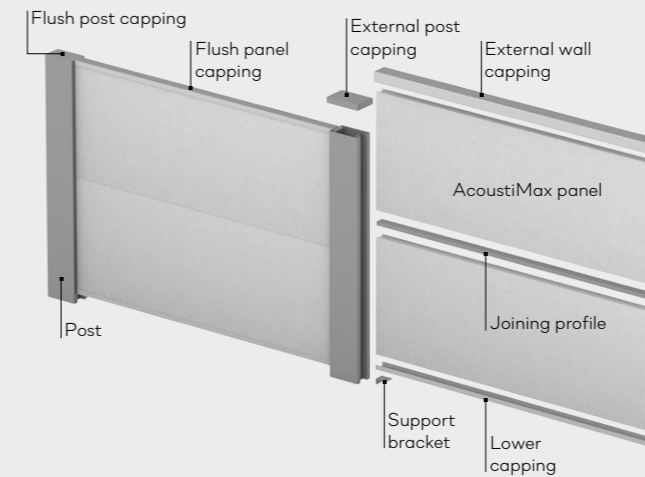

RETAIN UP TO 750mm

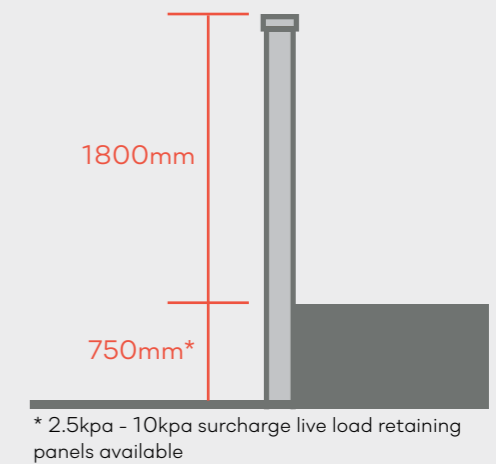

ACOUSTIMAX PANEL

- Fibre cement/EPS composite construction
- Lightweight
- Impact resistant
- Panel span up to 3 meters
- Can be cut or profiled as required

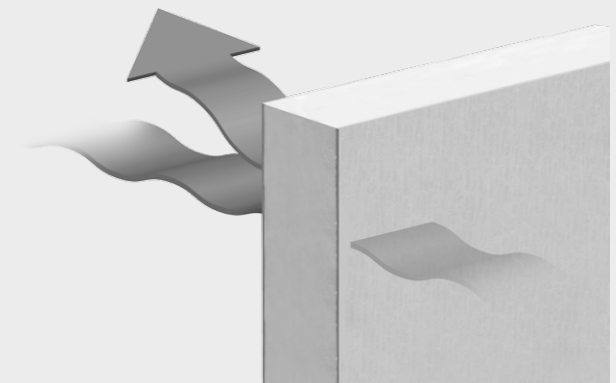

ACHIEVE A 4-FOLD NOISE REDUCTION (TYPICAL)

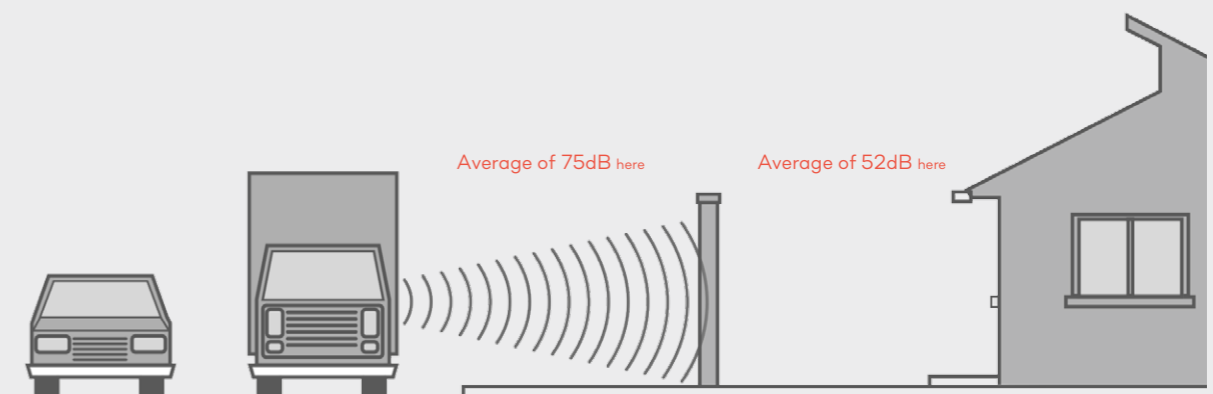

ABOUT US

With over 30 years' composite panel experience, ModularWalls is the leading manufacturer and pioneer of cost effective acoustic wall and panel solutions.

Our product range includes external prestige fencing, boundary walls, retaining walls, impact resistant noise barriers, and high-tech sound absorbing wall panels for both internal and external requirements.

Our walls offer a genuine alternative to a free-standing masonry wall. Based around our innovative composite wall panels and supported by a unique post system, our walls have been specifically designed to attenuate sound and mitigate noise.

The products are Australian designed and manufactured to strict international ISO 9001 quality standards. ModularWalls

products are applied in a wide variety of industries and government departments. We have supplied over 15,000 walls and other acoustic, retaining and impact resistant panel solutions across Australia, New Zealand, USA and Europe.

ModularWalls has proven to be an integral asset to our partners. Some of our Commercial and Civil clients include: BHP Billiton, Rio Tinto, Coles, Woolworths, McDonalds, KFC, Hungry Jacks, Bunnings, 7 Eleven, Aldi, Peet Group, Laing O'Rourke, Lend Lease, Sekisui House, Leighton Holdings, Energy Australia, RMS NSW, Main Roads WA, Main Roads QLD, AGL, Xstrata, Telstra and Origin Energy.

COMMERCIAL SOLUTIONS

ModularWalls not only provides acoustically rated masonry alternate walls that integrate perfectly with any residential home, our commercial acoustic walls are setting new benchmarks in sound attenuation that benefit whole communities.

ModularWalls has a proven performance record across thousands of commercial noise abatement, security, privacy and architectural projects having partnered with some of Australia's largest companies and government departments. ModularWalls are proud Australian manufacturers with a reputation for quality and innovation.





VogueWall Classic with flush post tops and external panel capping, customised with laser cut screens



MODULAR WALLS

15,000 SUCCESS STORIES AND COUNTING...

modularwalls.com.au

1300 556 957

